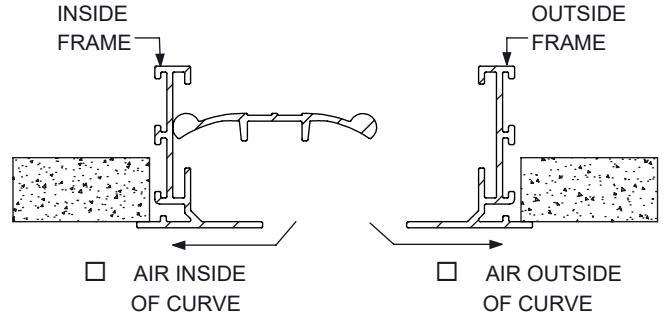
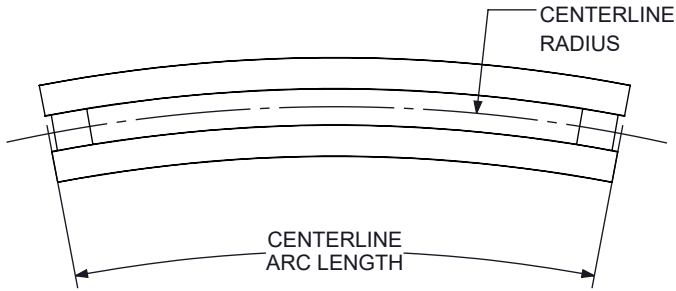
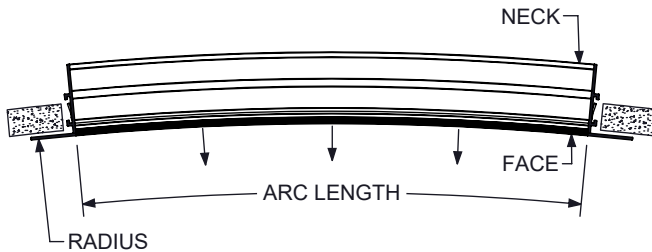
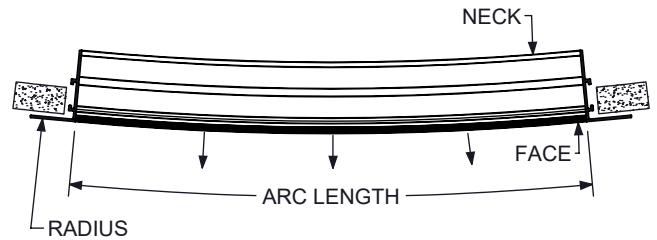

CURVED DFL™ - DESIGNFLO™
 ALUMINUM ARCHITECTURAL LINEAR DIFFUSER

SUBMITTAL SHEET
CURVED STYLE:
 CURVED

 CONCAVE

 CONVEX

FRAME STYLE :

-
- AA
-
-
- BB
-
-
- CC
-
-
- FF
-
-
- EE

SLOTS :

-
- 1 SLOT
-
-
- 2 SLOT
-
- SEE FORM GC0100 / GC0102

SLOT WIDTHS :

-
- 10 - 1"
-
-
- 15 - 1.5"
-
-
- 20 - 2"
-
-
- 25 - 2.5"
-
-
- 30 - 3"
-
- SEE FORM GC0100

PATTERN CONTROLLERS :

-
- 00 - NO BLADES

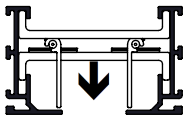

-
- VT (VERTICAL THROW)

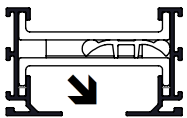

-
- HT (HORIZONTAL THROW)

END BORDER :

-
- BUTT CUT
-
-
- END PLATE / BUTT CUT
-
-
- END PLATES
-
-
- BUTT CUT / END PLATES
-
-
- END CAP/ BUTT CUT
-
-
- END CAPS
-
-
- BUTT CUT / END CAP

MOUNTING :

-
- SEE FORM GC0107

FINISH :

-
- 44 - BRITISH WHITE
-
-
- 01 - MILL
-
-
- 35 - BLACK
-
-
- 07 - ENAMEL PAINT MATCH
-
-
- 81 - CLEAR ANODIZE
-
-
- 84 - LIGHT BRONZE ANODIZE
-
-
- 85 - MEDIUM BRONZE ANODIZE
-
-
- 86 - DARK BRONZE ANODIZE

ARC LENGTH : _____

RADIUS : _____

NOTES :

- CONSTRUCTION IS EXTRUDED ALUMINUM WITH ENGINEERED POLYMER COMPONENTS
- CURVED LENGTHS GREATER THAN 72" [1829] ARE FURNISHED IN MULTIPLE SECTIONS
- PATTERN CONTROLLERS, 24" [610] LONG, CHANGE AIR FLOW DIRECTION AND VOLUME
- MINIMUM ARC LENGTH IS 12"
- USE CURVING REQUEST EXCEL SHEET LINK FOR CALCULATOR AND ORDERING
- INTERIOR WILL BE FLAT BLACK, EXCLUDING ANODIZED FINISHES

 KRUEGER
 CURVING
 REQUEST
 FORM

DIMENSION ARE GIVEN AS INCHES [MM]

Revision Date: 5/15/2024

Form: GC0115

Replaces: NEW SUBMITTAL

Product Information is Subject to Change Without Notice